

NOTES

- A. THE FIRE LINE SHALL BE DEFINED AS "THE LINE FROM THE RISER INSIDE THE BUILDING TO THE FIRST VALVE ON THE SYSTEM."
- B. MINIMUM FIRE LINE SIZE SHALL BE 6".
- C. A 1" DOMESTIC TAP CAN BE MADE ON A 6" FIRE LINE AND A 1-1/2" DOMESTIC TAP ON AN 8" FIRE LINE. TAP MUST BE MADE PRIOR TO BACKFLOW PREVENTOR.
- D. A FIRE HYDRANT SHALL BE INSTALLED WITHIN 100 FEET OF THE FIRE DEPARTMENT CONNECTION. LOCATION TO BE APPROVED BY THE FIRE DEPARTMENT.
- E. FIRE LINE CHARGES SHALL BE BASED ON SIZE OF RISER.
- F. CONTRACTOR SHALL INSTALL A REDUCED PRESSURE PRINCIPLE BACKFLOW PREVENTOR ON FIRE LINE PRIOR TO RISER.
- G. LIMITED AREA SPRINKLERS SHALL BE CONNECTED BEFORE METER.
- H. DOMESTIC SERVICE SHALL INCLUDE BACKFLOW PREVENTOR PRIOR TO METER. WATER METER SHALL HAVE BYPASS AND STRAINER.
- I. ALL MATERIAL AND CONSTRUCTION METHODS SHALL CONFORM TO CITY STANDARDS.
- J. PRIVATE WATER MAIN SHALL REMAIN PRIVATE UNLESS ACCEPTED BY THE CITY AND AN EASEMENT IS GRANTED.
- K. ALL FIRE LINES SHALL BE TESTED AT 200psi. SEE HYDROSTATIC TEST ON PAGE 800-5 FOR ADDITIONAL REQUIREMENTS. FIRE DEPARTMENT TO WITNESS AND APPROVE LINE FLUSHING AND TEST.

TESTING PROCEDURES FOR EXAMPLE #1

- A. FIRE LINE SHALL BE INSTALLED, INSPECTED AND CERTIFIED BY A STATE LICENSED FIRE LINE INSTALLER.
- B. PRIVATE WATER MAIN CAN BE INSTALLED BY THE GENERAL CONTRACTOR AND MUST BE INSPECTED BY THE CITY. CONTRACTOR SHALL PRESSURE TEST MAIN AND OBSERVED BY THE CITY. CITY SHALL PERFORM DISINFECTION AND BACTERIA TEST ON BOTH THE FIRE LINE AND PRIVATE WATER MAIN AFTER PRESSURE TEST HAVE BEEN PERFORMED AND APPROVED.

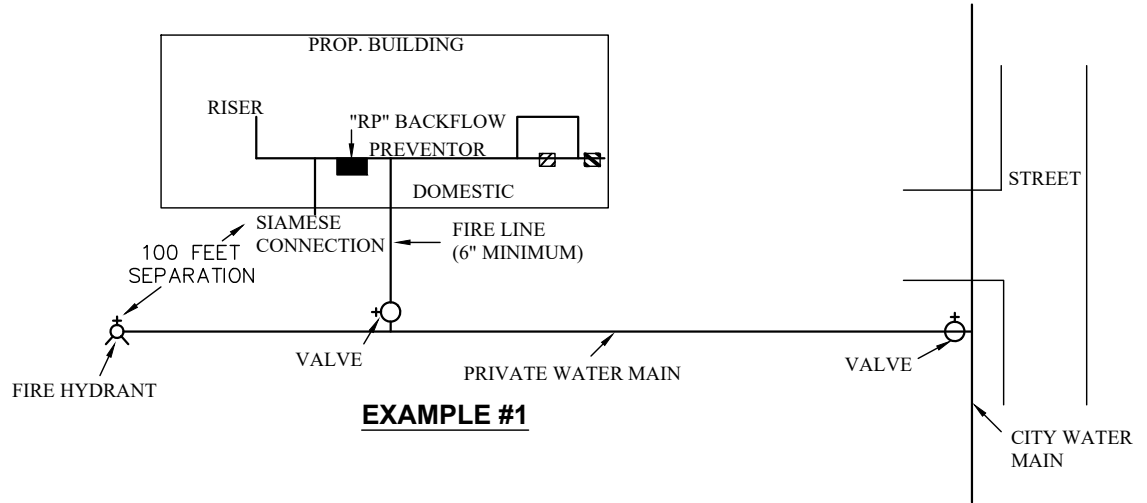

EXAMPLE #1

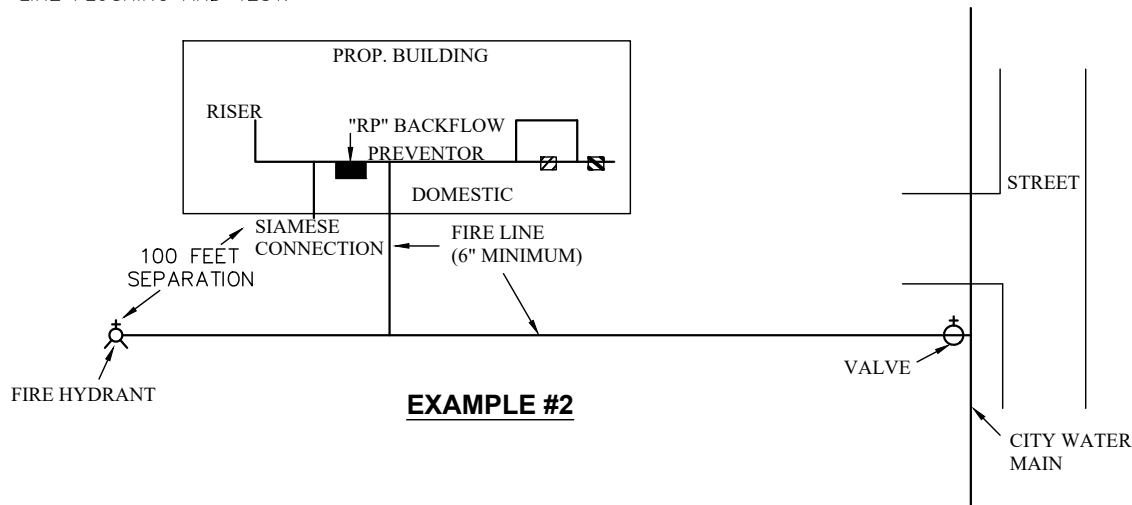

EXAMPLE #2

TESTING PROCEDURES FOR EXAMPLE #2

- A. ENTIRE WATER LINE SHALL BE CONSIDERED THE FIRE LINE PER THE DEFINITIONS.
- B. THE ENTIRE FIRE LINE SHALL BE INSTALLED, INSPECTED AND CERTIFIED BY A STATE LICENSED FIRE LINE INSTALLER.
- C. CITY SHALL PERFORM DISINFECTION AND BACTERIA TEST AFTER PRESSURE TEST HAS BEEN PERFORMED AND APPROVED.



FIRE LINE DETAIL AND NOTES

REVISIONS:	DATE APPROVED
	06/03/2020
	PAGE No.
	800-21